

# Design Document



## **Stethline**

Remote Online Stethoscope

## **CSE 453**

Hardware/Software Integrated Systems Design

## **Client**

Dr. Robert Gatewood

## **Team Members**

Tamaghan Maurya | tamaghan@buffalo.edu | Senior | Computer Science  
Michael Morgenthal | mmorgent@buffalo.edu | Senior | Computer Engineering  
Rayan Ray | rayanray@buffalo.edu | Senior | Computer Engineering  
Hasmeet Chawla | hasmeetc@buffalo.edu | Senior | Computer Engineering  
Jinyi Tao | jinyitao@buffalo.edu | Senior | Computer Engineering

# Table of Contents

<b>Cover page</b>	<b>1</b>
<b>Table of Contents</b>	<b>2</b>
<b>Background</b>	<b>3</b>
<b>Product Design</b>	<b>4</b>
Hardware	4
Parts List	5
Software	6
User Interface	6
Source Code	8
Frontend	8
Backend	8
<b>Milestones</b>	<b>8</b>
<b>Debugging</b>	<b>9</b>
Breadboard Circuit	9
Debugging Audio Quality:	10
Rebuilding Circuit:	10
<b>Upgrades</b>	<b>12</b>
<b>Appendix</b>	<b>13</b>

# I. Background

The changes brought to everyday life by COVID-19 have tested the limitations of existent medical practices and the normal setting they would occur in. In this modern age of technology, we saw many industries adapt to the new remote workstyle but fields such as those in the medical profession weren't able to do so due to a need to meet patients in person. For doctors to conduct examinations such as those on the lungs and heart for patients who required regular checkups, there arose a need for a new way to record this information and provide adequate medical feedback. Our product Stethline, which has been developed alongside working with Dr. Robert Gatewood aims to provide both the patients and doctors a way of satisfying this requirement for health checkups while being budget-friendly for the patients. With the availability of our web app, a patient can simply drop the audio files after following the doctor's instructions during a google meet session and the doctor will be able to access and listen to the files to get a gauge on the patient's current health status. Stethline can offer a stethoscope for a drastically lower price when compared to other telemedicine alternatives on the market for a price of around \$10. Our stethoscope will be able to connect to a patient's computer and/or iPhone and make use of the built-in recording apps to create audio files for use in our applications.

We aim with this product to help provide doctors and patients a way to continue conducting telemedicine visits to protect the well-being of both parties, but also not missing out on making sure the patient is being well taken care of. Telemedicine was being done before COVID-19 and till now we have seen it become a new way for people of all age groups to get their health checkups without leaving the comfort of their homes. We believe that Stethline will prove to be a useful product for patients to consider investing in if they choose to continue this method of appointments.

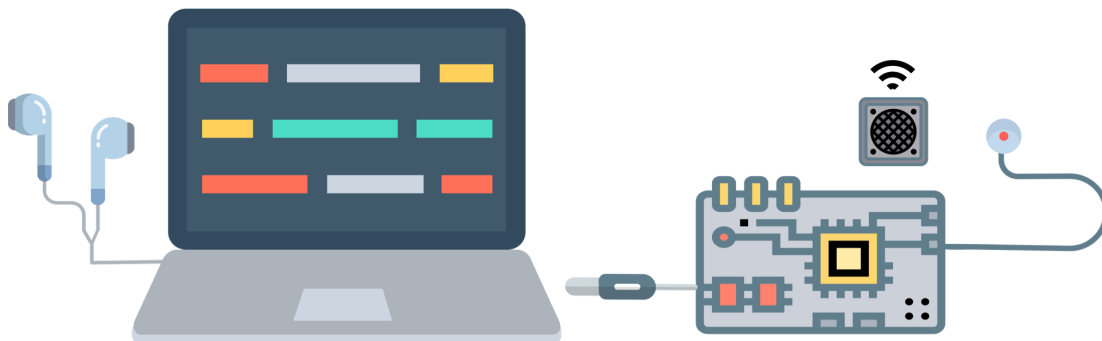

Figure 1: Stethline working connections

## II. Product Design

### a. Hardware

Stethline uses standard circuit design parts which are available in many kits readily available from retailers, parts including capacitors, resistors and jumper wires. We figured this would be the best approach to building the product since it is a cost-effective way of building circuits and all the parts are readily available in our CSE 453 Hardware/Software Integrated Systems lab, and are available in stores and online retailers such as Digi-Key Electronics and Amazon.

Our approach to accomplishing this project was to design the circuit on a standard solderless board, which leaves us with a lot of room and convenience for upgrades or any changes that may come up.

The main purpose of the circuit is to provide amplification to the collected audio from the mic. It uses Operational Amplifiers (OP-Amps) such as LM386 which are low powered audio frequency amplifiers which amplify the weak electrical signals from the source. These ICs are perfect for Stethline use since it consumes very less power and provides a variable gain from 20-200. Stethline amplifier circuit uses 2 of LM386 ICs which takes the audio input signal from the mic and increases its potential from 20-200 times.

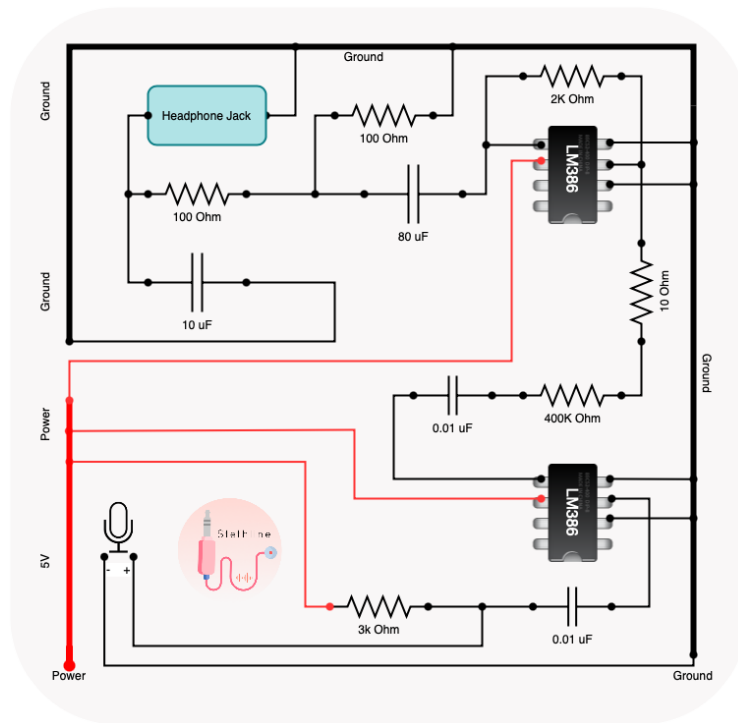

Figure 3: Stethline updated Circuit diagram

## Parts List

The project required amplification of very low electric signals so a custom op-amp circuit was added to the unit.

Bill of Materials:

Product	Quantity	Link
LM386 Op Amps	2	<a href="#">Link</a>
Electret condenser microphone	1	<a href="#">Link</a>
Budget Friendly Stethoscope	1	(readily available)
3.5mm male to male aux cable	1	<a href="#">Link</a>
3.5mm audio jack	1	<a href="#">Link</a>
0.01 microfarad capacitor	2	Available in Lab
10 microfarad capacitor	1	Available in Lab
80 microfarad capacitor	1	Available in Lab
3.5k ohm resistor	1	Available in Lab
100k ohm resistor	2	Available in Lab
400k ohm resistor	1	Available in Lab
2k ohm resistor	1	Available in Lab
Breadboard	1	<a href="#">Link</a>
Jumper wires	1	<a href="#">Link</a>
5V power source	1	Available in Lab

*\*readily available - Can buy from a general medical store.*

*\*Available in Lab - CSE 453 Lab.*

## **b. Software**

The software side of the Stethline provides easy accessibility to the connection between doctor and Stethline. It mainly includes a web application with back end side on the UB cheshire server and frontend side on HTML, CSS and bootstrap library. The Backend stores server-side PHP files for accessing/inserting database information. It's main purpose is to securely host the Stethline website.

Following the HIPAA Compliance, Stethline uses Google Meets to build an audio connection between stethoscope and doctor. A private Google Meet link will be created from the website upon clicking the “Use Now” button, so the patient can transform the audio gathered through our stethoscope via their second device.

### ***User Interface***

On the user facing side of this product, the web application can be accessed via the following link: [Stethline](#)

Where you will see a section giving brief information on the goal of the overall project, the features of our developed tools and diagrams detailing how the product works in conjunction with a laptop.

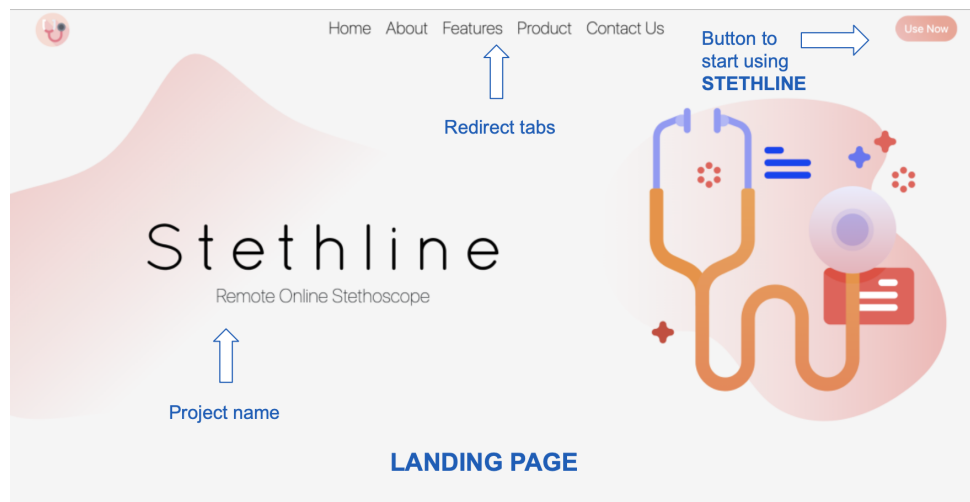

Figure 1: Landing Page of Stethline Web Application

In the top right there is a “Use Now” button which when pressed will give steps on entering email information and a reminder to plug in the stethoscope before proceeding into the meeting. The patient will be reminded to mute their microphone and turn off their camera, and to simply wait for the doctor to join the meeting and give instructions for the telemedicine appointment.

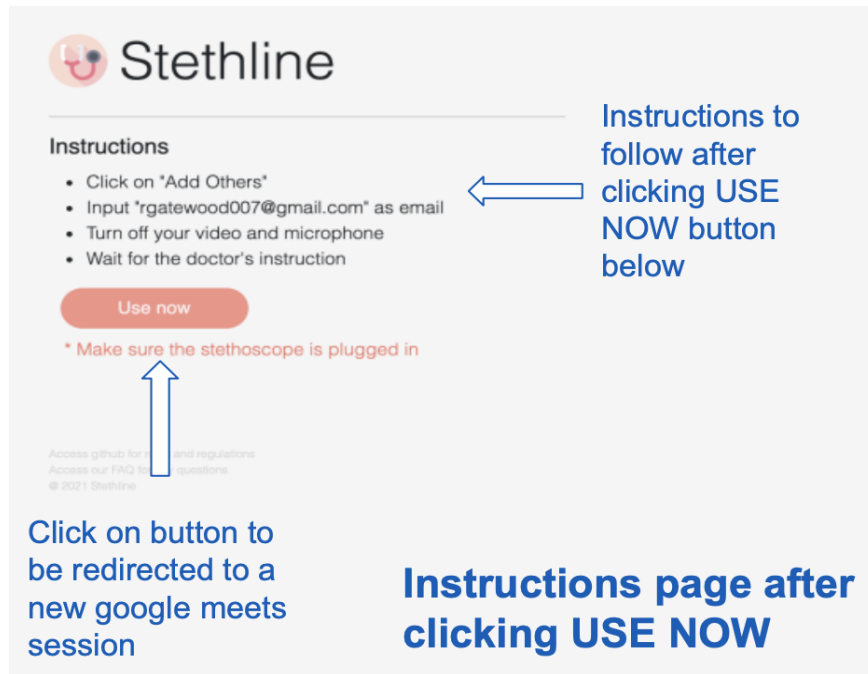

Figure 2: Screenshot of screen prompted when “Use Now” is pressed

The user interface on the doctors side will involve using Google Meets to join the meeting currently set for that telemedicine appointment, and making sure the patient has successfully joined as well. The doctor will also be able to receive the files for the patient which will be kept anonymous throughout the whole duration of the appointment in order to meet HIPAA compliance. The doctor will simply see audio clips which they will listen to in order to get an appropriate gauge on the patient’s lungs and heart.

## Source Code

### Frontend

The Stethline product web app is written in HTML and CSS and the source code for the design and functionality for the website itself is in this github repository for this project:

<https://github.com/mmorgent/Remote-Stethoscope-Web-App>

## Backend

The database where the code for the website and uploading of the audio files for the telemedicine appointments is set up on the University at Buffalo's Cheshire Server. Cheshire is an Apache HTTP Server running on CentOS and managed internally at UB. This can be implemented in any other appropriate server if the product is to be used by let's say the offices where Dr. Gatewood works in. Information regarding the UB Cheshire development server can be found at the following link:

<https://www-student.cse.buffalo.edu/tutorial/environment.php>

Access to the server is managed through requests from the UB CSE dept, in order to gain access to see the implementation of the server please send an email regarding your need for access to [cse-webmaster@buffalo.edu](mailto:cse-webmaster@buffalo.edu), and they will be able to help in regards to this.

## III. Milestones

Our project progress first started off brainstorming and speaking with our client Dr. Gatewood, and we came up with an approach which helped us to implement all of our ideas successfully and this are some of how milestones and progress throughout the last 15 weeks:

1. Identified the main attributes behind our product which were to provide accessibility and usability for all to use in a remote manner.
2. We worked to create a plan for incorporating hardware components, the front end UI for the web app and the cheshire database together to accomplish our goals.
3. Researched different streaming methods and decided that google meets would be the choice for our product, since it worked well within our HIPAA guidelines and streaming goals.
4. Moved forward with a front end UI which met professional standards, easy to follow for users and achieved through HTML/CSS and Bootstrap.
5. Completed server setup on Cheshire and merged the front end web app into the server to fully accomplish a major part of our project.
6. Started on the Initial Build Phase of the physical product and noted any more parts that would be required for the testing phase.
7. Started the testing phase for the audio clips we hoped to see, and saw where our technology could be improved to account for clearer audio.



8. Went through circuit debugging and adjusted our circuit to include band pass filter to result in
  - a. Almost complete elimination of noise
  - b. Reduced delay of transmission
  - c. Sound proved to be loud and audible
9. Identified any future improvements that we recommend to be made to bring this product to the next level.
10. Collaborated and completed User Design Doc, Engineering Notebook and Final Presentation for the client and class to see.

## **IV. Debugging**

### ***Breadboard Circuit***

When the circuit is connected to an adjustable power source we recommend using the two plugs on the top of the breadboard and running a wire through the hole on the bottom to relay power and ground to the respective rails on the breadboard. Please refer to the following steps:

1. Ensure all components have their respective ground pins accounted for and connected.
2. Plug in the ground and power plugs from the source to the board itself.
3. Using a voltmeter ensures that the voltage coming out of the power source is around 5.00 V, the most we have tested with was approximately 6.82 V and the circuit was functioning as intended at that level.
4. Take a few seconds to simply place your finger over the LM386 chips and make sure they are not heating up and make sure to do the same for other major components i.e. resistors, capacitors and microphone jack.
5. Plug in 3.5 mm wire into the headphone jack and ensure the audio coming out is as intended, the following information will help with debugging any issues in the audio quality.
6. Remember not to pull any cable, since the current version is a prototype and breadboard does not provide strong wire connections.

### ***Debugging Audio Quality:***

During testing of our design we experienced issues dealing with the audio quality coming from the circuit we built. This is where we decided to implement a passive band pass filter to help cut down on this noise coming in. A passive band pass filter incorporates two capacitors to work as a second-order type filter. This helped us to achieve a more clear audio output where we are able to hear the heartbeat of the person testing the circuit.

Following are the steps to rebuild the passive band pass filter:

1. Two resistors will be required which of both will be 100 ohm, and two capacitors of which one will be 80 mF and the other will be 10 mF.
2. The layout of the passive band filter follows this pattern
  - a.  $V_{IN}$  comes in from the LM386 chip and will be relayed into the filter
  - b. First component after that will be the 100 ohm resistor, which right after in series with it is the first capacitor
  - c. In parallel to the first resistor, we will place the second capacitor we have.
  - d. In parallel with that second capacitor we will have our second 100 ohm resistor.
  - e.  $V_{out}$  will be produced from the right hand side of this filter and will be wired to the microphone jack we have.

### ***Rebuilding Circuit:***

If during the use of the product there are issues with the board itself frying and components experiencing damage here are the steps to rebuilding the circuit and testing to make sure the product is rebuilt correctly. Before starting this process, please make sure you follow proper safety procedures by using safety glasses and using a power source in a responsible manner.

- The engineer should get the double sized breadboard and first start off with placing two LM386 chips on the middle rail of the breadboard, making sure that the pins are secured into the slots of the board and the half circle is facing to the left towards the plugs for power and ground. We recommend, since the board is a bigger size, to put one chip dedicated for input from the user on one half of the entire board and the other chip will take the other spot.
- Pin 2 and 4 of the LM386 chip must be grounded to the side rails of the board and start on the one at the most left side of the board for building. This chip will be responsible for taking input from the user for listening to the heartbeats,

therefore you should connect pin 6 of the chip to power and Pin 3 will serve as the input from the microphone.

- The microphone is connected at the corner of the board to allow for room to keep everything a respectable distance from each other. The black wire on the microphone is connected to the ground rail on the side of the board, and the red wire is routed to a 0.01 mF capacitor which will then provide input to Pin 3 on the first LM386 chip. This output will be coming out of Pin 5 of the chip and this will be outputted using a jumper wire and into a 0.01 mF capacitor and 400 K ohm resistor and connected to Pin 3 of the second LM386 chip.
- For the second LM386 chip we will also be connecting ground pins to the respective rails and the other remaining pin to work with on this second chip will be Pin 6 to output to the microphone jack. This should be outputted using another jumper wire and relayed through a 2k ohm resistor and 80 mF capacitor. This will be inputted into the microphone jack in accordance with the capacitor and resistor used for those pins on the jack.
- The pins on the microphone jack should be soldered to jumper wires to ensure a more secure connection. This task could be accomplished with alligator clips as well but during the testing phase we found alligator clips to not be as reliable for an audio output. One of the pins which we have used a grey jumper cable for will be connected to the ground rail and the other one in purple will have the capacitor and resistor connected to it. When the output from pin 6 of the second LM386 chip is relayed through that capacitor and resistor we will get the final output for the headphone jack.

Please refer to the final circuit built image in the hardware section. [Here](#)

To give you a perspective of how large the circuit is and how wires are placed as far as possible to avoid voltage noise issues, refer to the image below:

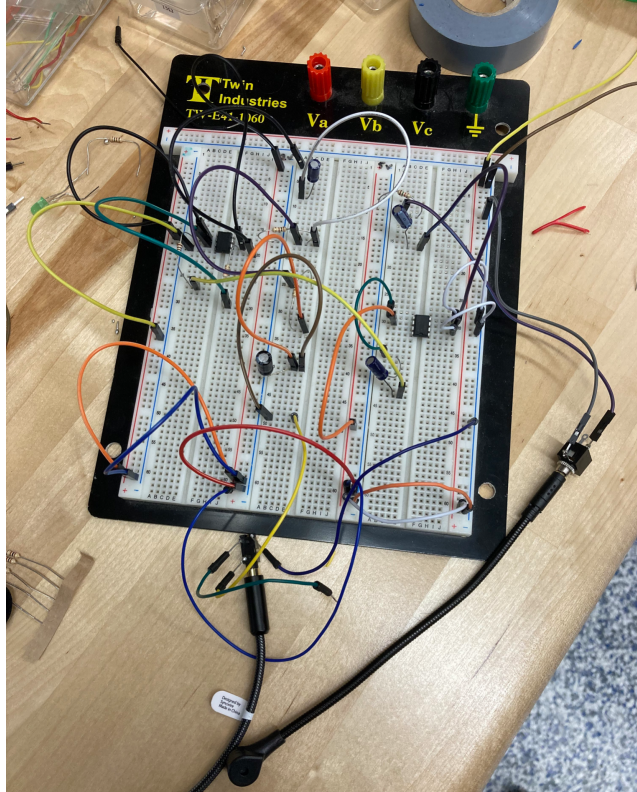

Figure 4: Picture of the physical circuit on breadboard taken during final testing phase

## V. Upgrades

Following are some upgrades Stethline needs in order to be ready for public use:

- Implementation of custom audio streaming service without third party dependence.
- Integrate current breadboard build into a custom PCB or at least a soldered breadboard to strengthen circuitry and further reduce noise.
- Use LM358 which is more suited for small scale electret condenser microphones.
- Switch from electret microphones to contact microphones.
- Have a separate Stethline product which will cut the need for users to buy separate stethoscopes and then attach it to the build.
- Improve security associated with doctor and client meetings after introducing an independent platform.

## VI. Appendix

Figure 1: Landing page of web application

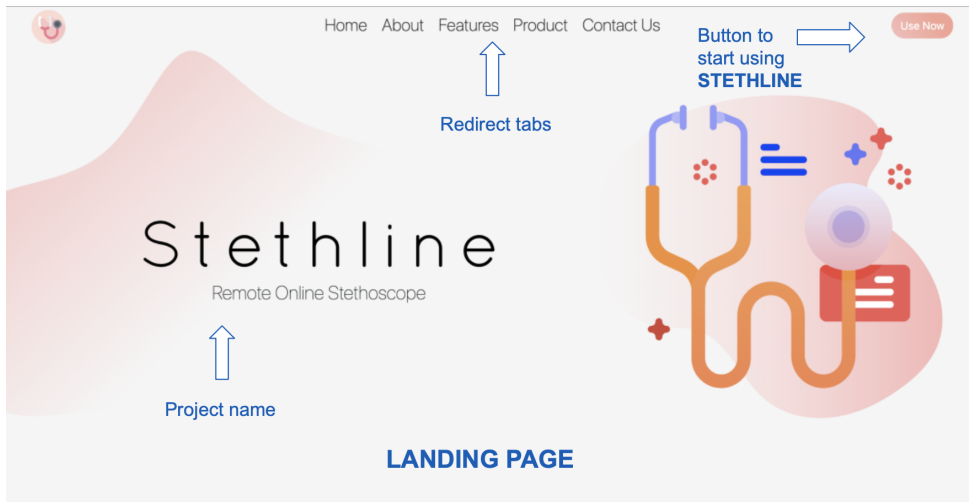

Figure 2: Screenshot of screen prompted when "Use Now" is pressed

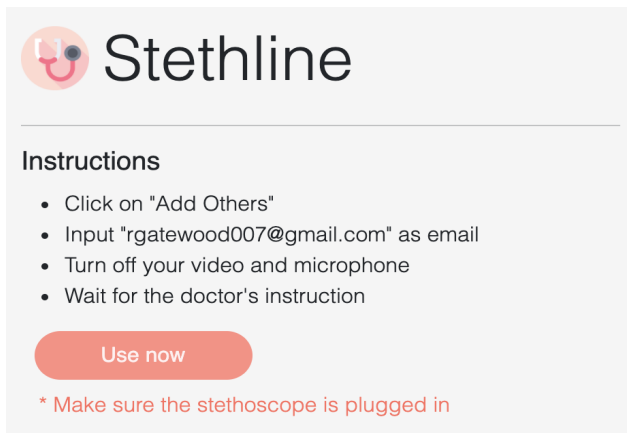

Figure 3: Stethline updated Circuit diagram

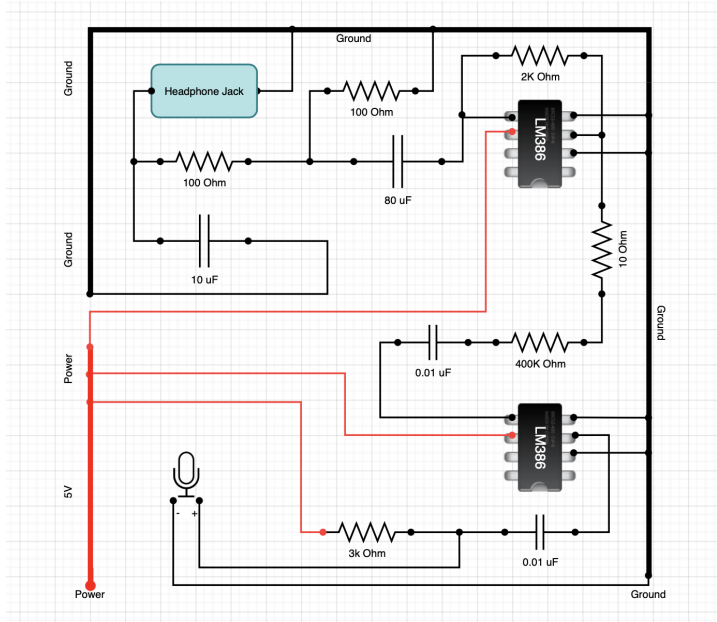

Figure 4: Picture of the physical circuit on breadboard taken during final testing phase

